



FM-24 Media Flow Monitor

for the 70-24 Media Flow Sensor

Instruction Manual



56790 Magnetic Drive, Mishawaka, Indiana 46545 USA • 1-800-832-5653 or (574)256-5001 • www.electronics-inc.com

Table of Contents

Product Overview	3
Principle of Operation	3
Factory Default Settings	4
Preliminary Settings	5
Zero	5
Full Scale Display Range	5
Alarms	5
<i>Alarm Band</i>	5
<i>Alarm On/Off</i>	5
<i>Alarm Delay</i>	5
<i>Alarm Reset</i>	5
<i>Alarm Mode</i>	5
Operation	6
Setpoint	6
Enable	6
Process Input Signal	6
Wiring	7
Specifications	10
Dimensions	10
Installation	11
Electronics Inc. Contact Information	12
Limited Warranty	13

READ INSTRUCTION MANUAL COMPLETELY BEFORE OPERATING THE FM-24 Monitor

Product Overview

The FM-24 Media Flow Monitor is used with Electronics Incorporated Media Flow Sensors for air-blast and wheel-blast shot peening and blast cleaning machines. The FM-24 Monitor displays the media flow rates based upon a 0-10 Vdc output signal proportional to the media flow rate signal. High/low alarms are set to bracket the requested media flow rate.

Principle of Operation

Media flow sensors from Electronics Incorporated provide an output signal proportional to media flow rate for either ferrous or non-ferrous media. The media flow value is shown in the FM-24 Monitor's digital display and is provided as 0-10 Vdc output signal for data acquisition systems. Alarms are available to indicate flow conditions outside of settable limits. The expected media flow rate is input as a Setpoint and the high-low alarms are based upon deviations from that value.

Factory Default Settings

Adjustments to the factory default settings can be made at the Operator Control Panel and the Technical Adjustments Panel (located behind the lower panel cover plate).

Control Panels

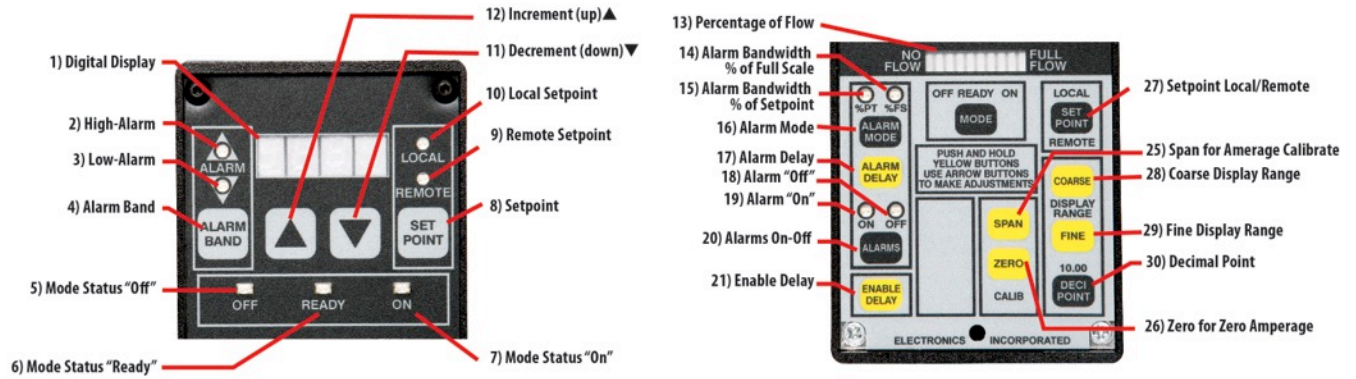

Default Settings

Button Number	Feature	Factory Default Setting
16	Alarm Mode	%FS (% of Full Scale)
4	Alarm Bandwidth	5%
17	Alarm Time Delay	5 Seconds
20	Alarm On/Off	On
21	Enable Delay	5 Seconds
22	Enable Mode	Ready
28	Full Scale Display (Coarse)	30.0
29	Full Scale Display (Fine)	30.0
25	Calibration - Span	1.000
26	Calibration - Zero	0.00 Vdc

Preliminary Settings

Note: Refer to Operator Control Panel and Technical Adjustment Panel diagrams in the “Factory Default Settings” section for location of buttons.

Zero

The digital display (1) should read 0.0 when the Media Flow Sensor is off. If it does not read 0.0, push and hold the Zero button (26) and use the down button ▼(11) or up button ▲(12) as required to achieve zero.

Full Scale Display Range

The full-scale range is set to match the Media Flow Sensor calibration (for example: 30 lb/min). The full-scale range is set to 30 lb/min by default. To display the value of the Full Scale Display Range, press and hold the Coarse or Fine Display Range button (28/29). To change the value, press and hold the Coarse or Fine Display Range button (28/29) and use the down button ▼(11) or up button ▲(12) as required.

Alarms

Alarm Band

The high and low alarm relay contacts react when the flow rate is lower or higher than the alarm bandwidth setting. The factory setting is $\pm 5\%$ of full scale. The center of the Alarm band is the Setpoint Command. To display the range of the alarm band, press and hold the Alarm Band button (4). To change the value, push and hold the Alarm Band button (4) and push the down button ▼(11) or up button ▲(12) as required.

Alarm On/Off

The Alarm On/Off (20) button will toggle the alarm on and off. When the alarms are off (indicated by the Alarm Off LED (18), the FM-24 will monitor the flow rate from the connected media sensor, but will not turn on the high or low alarm if the flow rate goes outside the alarm band. Push the Alarm On/Off button (29) to select either Alarm On (19) or Alarm Off (18). The factory setting is On.

Alarm Delay

The High Alarm LED (2) or Low Alarm LED (3) will illuminate whenever the flow rate is outside the Alarm Band Setting. These LEDs will get brighter at the expiration of the alarm time delay and the alarm relay contacts will transfer and latch. Press and hold the Alarm Delay button (17) to display the alarm time delay. The factory setting for the alarm time delay is 5 seconds. To modify this value, press and hold the Alarm Delay button (17) and push the down button ▼(11) or up button ▲(12) as required.

Alarm Reset

Application of the next enable signal will reset the alarm. Momentary application of 24 Vdc signal to screw terminal 12 will also reset the alarm. Continuous application of 24 Vdc signal to screw terminal 12 will disable the alarm.

Alarm Mode

Push the Alarm Mode button (16) to select either percent of Full-Scale Range “%FS” (14) (most common) or percent of Setpoint “%SP” (15). The factory setting is %FS.

Operation

Note: Refer to Operator Control Panel and Technical Adjustment Panel diagrams in the “Factory Default Settings” section for location of buttons.

Setpoint

The setting for the desired flow rate may come from a remote source, such as PLC, or it may be set from the FM-24. To set or change the Setpoint, push the Setpoint Local/Remote button (27), select “Local”, then push the Setpoint button (8) to display the value. To change the Setpoint value, push and hold the Setpoint button (8) and use the Down button ▼ (11) or Up button ▲ (12) as required.

Enable

The Mode button (22) will select the enable status. The choices are Off, Ready and On. The On mode will transmit an enable signal to the Media Flow Sensor to commence flow. The Ready mode will transmit the enable signal only when a remote enable signal (from a PLC, for example) is received. The Off mode prevents any operation of the Media Flow Sensor—it will ignore the remote enable command. Note: the Enable Delay (21) will delay the enable signal to the Media Flow Sensor if set greater than 0 seconds.

Note: The Enable Delay (21) will delay the enable signal to the Media Flow Sensor if set greater than 0 seconds. This can be helpful if turbulence or unstable operation occurs at the beginning of the cycle.

Process Input Signal

The process input signal is 0-10 Vdc from the Media Flow Sensor. A signal of 10.0 Vdc indicates a full-scale signal from the Media Flow Sensor.

Wiring

Terminal Schematic

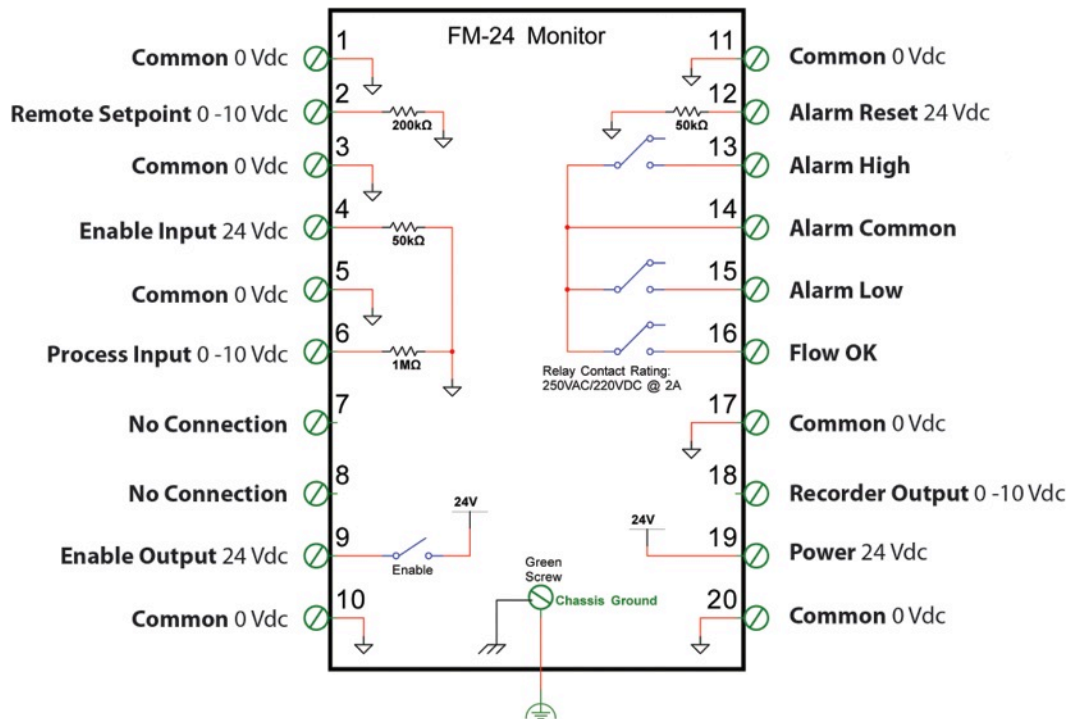

Note: Refer to Operator Control Panel and Technical Adjustment Panel diagrams in the “Factory Default Settings” section for location of buttons and LEDs. Refer to the Terminal Schematic above for the location of the terminals.

Terminal Descriptions

2 - Remote Setpoint

Push the Setpoint Local/Remote button (27) until Remote Setpoint LED (9) is on. Apply a 0-10 Vdc analog signal to the Remote Setpoint terminal (2). A zero Vdc signal will correspond to a 0% flow rate command and a 10 Vdc signal will correspond to a 100% flow rate command. To display the Remote Setpoint command, push Setpoint button (8). The Remote Setpoint command may come from a remote potentiometer or any other 0-10 Vdc signal source.

4 - Enable Input (24 Vdc)

When a 24 Vdc signal is applied to the Enable Input terminal and the mode is in the Ready state, the FM-24 will output a 24 Vdc signal on the Enable Output terminal (9) and turn the Mode Status “On” LED (7). The Enable Output terminal (9) is normally connected to the Enable Input wire of the Media Flow Sensor (blue wire). The Enable Input signal will reset alarms that occurred during the last cycle.

6 - Process Input (0-10 Vdc)

This 0-10 Vdc process input represents the flow rate of the media through the Media Flow Sensor. Zero (0) Vdc input represents 0 lb/min or 0 kg/min and 10 Vdc represents the maximum calibrated flow rate (see Full Scale Display Range under Preliminary Settings). The signal is displayed on the Operator Control Panel’s digital display (1). When 10 Vdc is applied, the FM-24 will display the number set for the Display Range (28/29). The Process Input terminal (6) is normally connected to the Analog Output of the Media Flow Sensor (white wire).

7

Not used on the FM-24.

8

Not used on the FM-24.

9 - Enable Output (24 Vdc)

- When the mode is in the Ready state and an Enable Input signal is received, an Enable Output signal is generated at terminal #9.
- When the mode is in the On state, an Enable Output signal is generated at terminal #9.
- When the mode is in the Off state, no Enable Output signal is generated at terminal #9.

The Enable Output terminal (9) is normally connected to the Enable Input wire of the Media Flow Sensor (blue wire).

12 - Alarm Reset (24 Vdc)

When a 24 Vdc signal is temporarily applied to the Alarm Reset terminal (12), all alarms will be reset. If a constant 24 Vdc signal is applied to the Alarm Reset terminal (12), the alarms will be held in the reset state, essentially disabling them.

13 - Alarm High

The Alarm High relay contact (13) is a normally open relay contact. The Alarm High relay contact (13) will close if the Process Input (6) is higher than the Setpoint value (8) plus the Alarm Band value (4) for duration longer than the Alarm Delay (17). The Alarm On-Off (20) must be On for alarms to work.

14 - Alarm Common

This is a common connection to all relays.

15 - Alarm Low

The Alarm Low relay contact (15) is a normally open relay contact. The Alarm Low relay contact (15) will close if the Process Input (6) is lower than the Setpoint value (8) minus the Alarm Band value (4) for duration longer than the Alarm Delay (17). The Alarm On-Off (20) must be On for alarms to work.

16 - Flow OK

The Flow OK relay contact (16) is a normally open relay contact. The Flow OK relay contact (16) will close if the Process Input (6) is at the Setpoint and within the Alarm Band (4) and will remain closed for the duration of the blasting / peening cycle. If the Process Input (6) goes higher or lower than the Setpoint value (8) and the Alarm Band value (4) goes for longer than the Alarm Delay (17), the Flow OK relay contact (16) will open and remain open until the alarms are reset. The Alarm On-Off (20) must be On for any of the alarms to work (press the Alarm On-Off button (20) and ensure the Alarm On LED (9) is lit).

18 - Recorder Output (0-10 Vdc)

This is the 0-10 Vdc analog output. The Recorder Output terminal (18) is typically connected to a PLC or some other monitoring equipment. The output represents the flow rate. Zero (0) Vdc represents 0 lb/min flow rate and 10 Vdc represents maximum flow rate.

19 - Power (24 Vdc)

The Power terminal (19) is the power supply input to the FM-24 and is connected to the positive terminal of the +24 V power supply.

20 - Common (0 Vdc)

The Common Power terminal (20) is the power supply return of the FM-24 and is connected to the negative terminal of the +24 V power supply.

Specifications

Power	+24 Vdc @ 0.5 A
Inputs	
Flow Sensor Input	0-10 Vdc into 100 K
Outputs	
Flow Enable Output	24 Vdc
Weight	1.3 lb/.59 kg
Display Range	0-1999
Decimal Points	1000, 100.00, 10.0
Alarm Band	0-50% of full scale
Alarm Delay	0-10 seconds
Enable Delay	0-10 seconds
Temperature Range	(32°F - 122°F) 0°C - 50°C

Dimensions

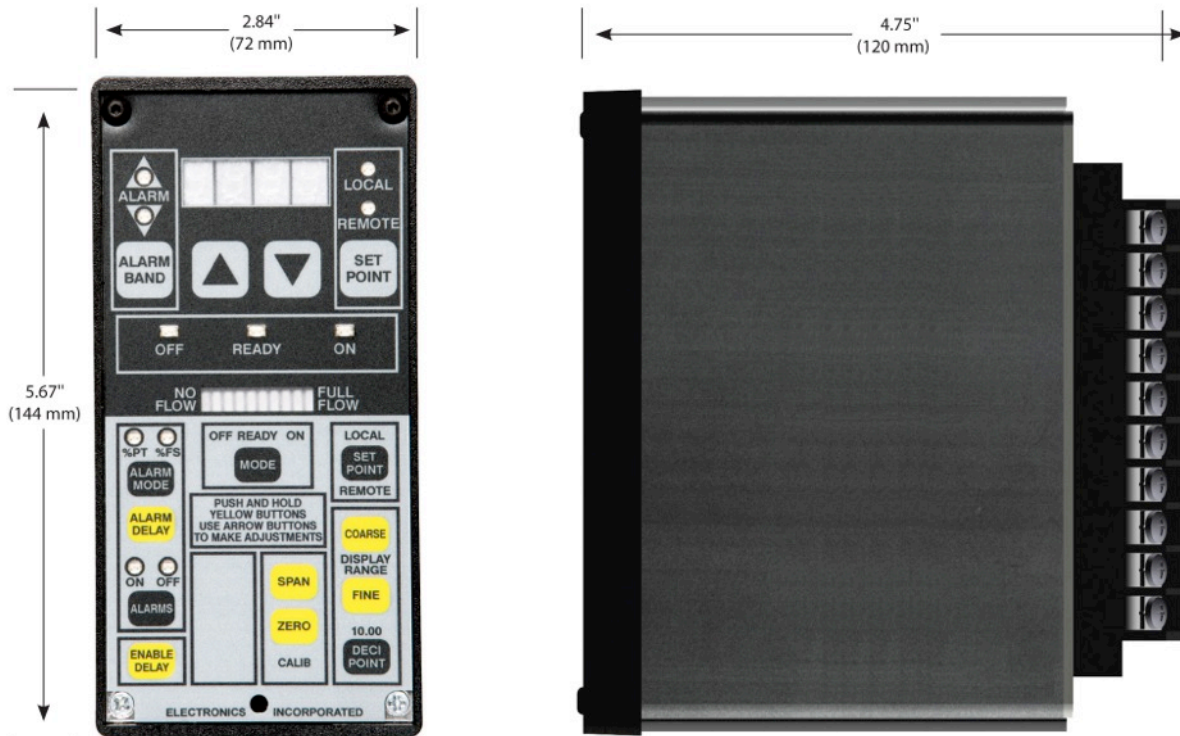

Shown with front panel removed

Panel Cutout Dimensions:
2.64" W x 5.35" H (67 mm x 136 mm)

DIN opening

Installation

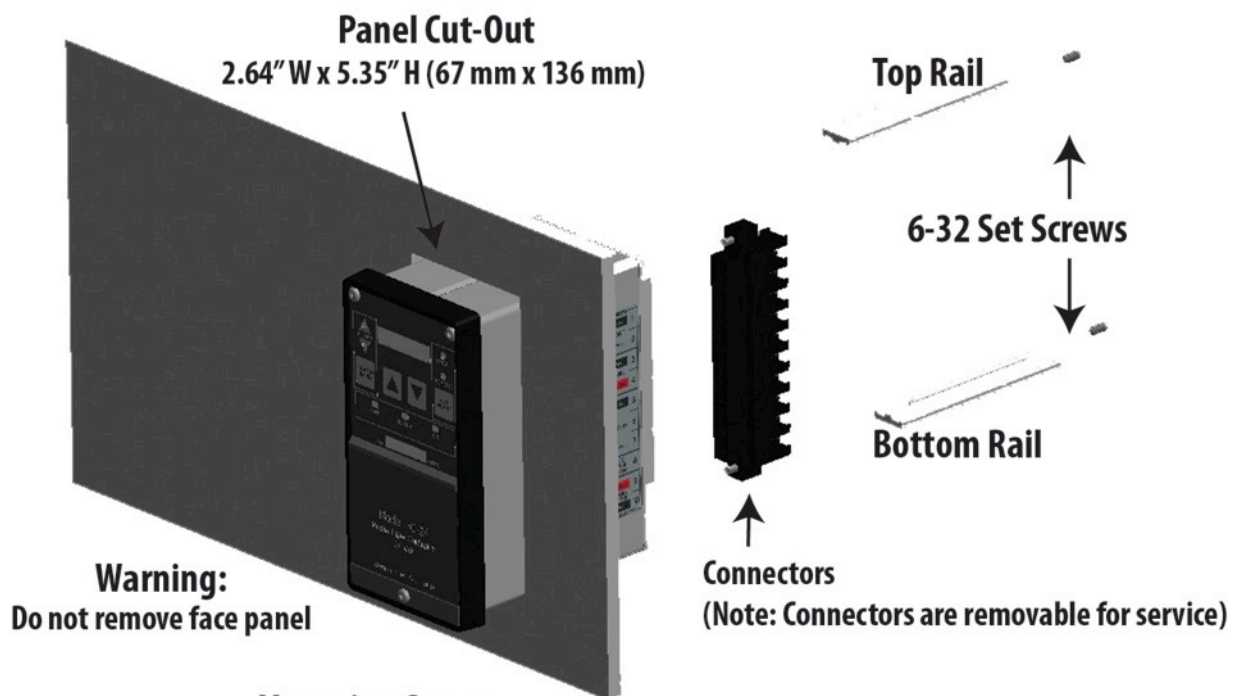

Mounting Steps:

- 1) Remove set screws and remove top and bottom rails from controller
- 2) Slide controller into panel from front
- 3) Slide rails back onto controller, reinstall set screws

Electronics Inc. Contact Information

Mailing and Shipping Address

Electronics Inc.
56790 Magnetic Drive
Mishawaka, IN 46545 USA

Telephone

1-800-832-5653 (Toll-free in USA and Canada) or (574) 256-5001

Fax

(574) 256-5222

Website

www.electronics-inc.com

For our warranty terms and shipping instructions, please read the Limited Warranty.

Limited Warranty

FM-24 Monitor

The warranty obligations of Electronics Inc. for this product are limited to the terms set forth below.

Length of Warranty Period

This limited warranty lasts one (1) year from the shipping date of this product.

What is Covered

This limited warranty covers defects in materials and workmanship in this product.

What is Not Covered

This limited warranty does not cover any damage, deterioration or malfunction resulting from any alteration, modification, improper or unreasonable use or maintenance, misuse, abuse, accident, neglect, exposure to excess moisture, fire, improper packing and shipping (such claims must be presented to the carrier), lightning, power surges, or other acts of nature. This limited warranty does not cover any damage, deterioration or malfunction resulting from the installation or removal of this product from any installation, any unauthorized tampering with this product, any repairs attempted by anyone unauthorized by Electronics Inc. to make such repairs, or any other cause which does not relate directly to a defect in materials and/or workmanship of this product. This limited warranty does not cover equipment enclosures, cables or accessories used in conjunction with this product.

How to Obtain a Remedy Under this Limited Warranty

To obtain a remedy under this limited warranty, contact Electronics Incorporated by letter, email, fax or telephone with the following information:

- Product name and model
- Product serial number
- Original shipping date (see label on product)
- Company name and location
- Name of contact person for description of symptoms
- Return shipping address and any special instructions

If it is determined that the product must be returned under this limited warranty, a Returned Goods (RG) number, obtained from Electronics Inc., will be required. This product should be properly packed to prevent damage in transit. Cartons not bearing a RG number will require additional processing time and repair service may be delayed.

What Electronics Inc. Will Do Under This Limited Warranty

Electronics Inc. will, at its sole discretion, provide one of the following remedies to whatever extent it shall deem necessary to satisfy a proper claim under this limited warranty:

1.) Elect to repair or facilitate the repair of any defective parts within a reasonable period of time, free of any charge for the necessary parts and labor to complete the repair and restore this product to its proper operating condition. Electronics Inc. will pay the shipping costs necessary to return this product once the repair is complete.

2.) If the defective product cannot be repaired, it will be replaced with a new unit and the original warranty period will be extended by six (6) months. Electronics Inc. will pay the shipping costs necessary to replace this product.

If this product is returned to Electronics Inc., the product must be insured during shipment, with the insurance and shipping charges prepaid. If this product is returned uninsured, Electronics Inc. does not assume any risk of loss or damage during shipment. Electronics Inc. will not be responsible for any costs related to the removal or re-installation of this product.

Out-of-Warranty Product

Product that is out-of-warranty will be repaired at customer's request and the cost of repair will be disclosed prior to proceeding with the repair. A purchase order must be received prior to repair. If the product cannot be repaired, Electronics Inc. will provide one of the following remedies:

- 1) New unit at current pricing with a one (1) year Limited Warranty from the shipping date of product.
- 2) Refurbished unit (if available) at a discounted price with a six (6) month Limited Warranty from the shipping date of product.

Limitation on Liability

The maximum liability of Electronics Inc. under this limited warranty shall not exceed the actual purchase price paid for the product. Electronics Inc. is not responsible for direct, special, incidental or consequential damages resulting from any breach of warranty or condition, or under any other legal theory to the maximum extent permitted by law.

Exclusive Remedy

To the maximum extent permitted by law, this limited warranty and the remedies set forth above are exclusive and in lieu of all other warranties, remedies and conditions, whether oral or written, express or implied. To the maximum extent permitted by law, Electronics Inc. specifically disclaims any and all implied warranties, including, without limitation, warranties of merchantability and fitness for a particular purpose. If Electronics Inc. cannot lawfully disclaim or exclude implied warranties under applicable law, then all implied warranties covering this product, including warranties of merchantability and fitness for a particular purpose, shall apply to this product as provided under applicable law.

Rights under State Law

This warranty defines specific legal rights relative to these products provided by Electronics Inc. Legal rights may also vary from state to state.