

Learning Zone

THE ELECTRONICS INC. PROBLEM SOLVER SERIES

The Benefits of a Closed-Loop System

by Jack Champaigne, Electronics Inc. Reprinted with permission from *The Shot Peener* magazine, Spring 2012

Open-loop and closed-loop are control systems. Open-loop systems operate in a “manual” mode (requires a person to manually review and make adjustments) while closed-loop systems operate in an “automatic” or self-adjusting mode. Here are automotive examples of the systems:

Open-Loop	Closed-Loop
Manual Transmission	Automatic Transmission
Manual Windshield Wipers	Rain-Sensing Wipers
Gas Pedal (Throttle)	Speed Cruise Control

The open-loop systems achieve an output state at some equilibrium (steady state) point. The closed-loop systems have the additional benefit of measuring the output and comparing it with the request, making adjustments as needed.

Consider a car’s cruise control, which is designed to maintain vehicle speed at a constant or reference speed provided by the driver. The controller is the cruise control, the plant is the car, and the system is the car and the cruise control. The system output is the car’s speed, and the control itself is the engine’s throttle position which determines the RPM of the engine.

A primitive way to achieve speed control is simply to lock the throttle position. This is great if you are traveling on flat and level terrain. If the terrain changes, the car will

travel slower going uphill and faster when going downhill. This type of controller is called an open-loop controller because no measurement of the system output (the car’s speed) is used to alter the control (the throttle position). As a result, the controller can’t compensate for changes acting on the car, such as a change in the slope of the road.

In a closed-loop control system, a sensor monitors the system output (the car’s speed) and feeds the data to a controller which adjusts the control (the throttle position) as necessary to maintain the desired system output (matches the car’s speed to the reference speed). Now when the car goes uphill, the decrease in speed is measured and the throttle position is changed to increase engine power, thereby increasing the speed of the vehicle. Feedback from measuring the car’s speed has allowed the controller to dynamically compensate for changes to the car’s speed. It is from this feedback that the paradigm of the control loop arises: the control affects the system output, which in turn is measured and looped back to alter the control.

Is there an advantage to using closed-loop control in media feed rate systems? Yes. One of the biggest advantages is convenience. Just like with cruise control, you can achieve and maintain a desired condition.

Another advantage is the simplicity of determining an optimum operating condition that allows you to reduce the flow rate to the minimum value that will achieve the desired results. This can be especially helpful in abrasive blast cleaning systems where annual media consumption and equipment maintenance are large expenditures.

Let’s look at some examples of open-loop and closed-loop systems in wheel blast systems. (You can also apply these schemes to air blast applications.)

In the open-loop system with a manual slide gate in Figure 1, the media flow rate is established by the position of a movable

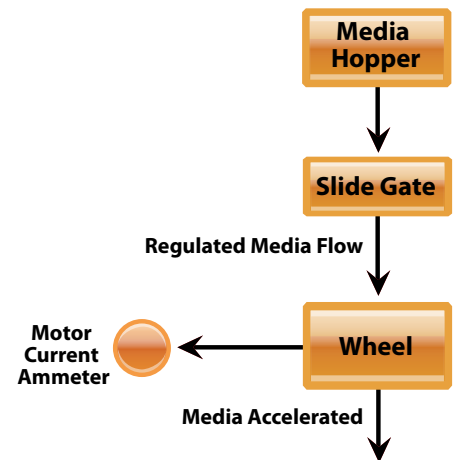
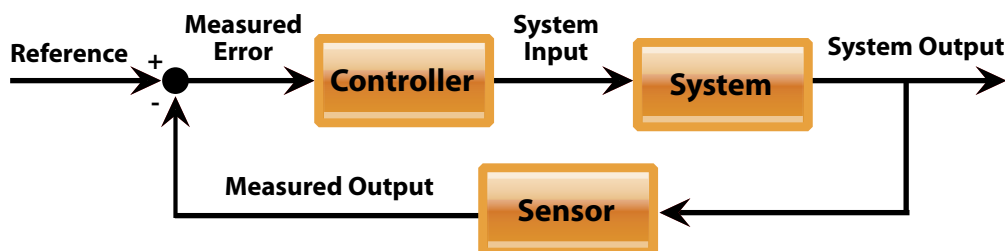

Figure 1. Open-Loop: Manual Slide Gate



This closed-loop system maintains the desired system output at the reference input because the sensed value is subtracted from the desired value to create the error signal, which is amplified by the controller.

slide in the flow path between the media hopper and the throwing wheel. Opening or closing the slide will increase or decrease the media flow rate which will be reflected by the motor current needed to accelerate the media. An operator is expected to visually monitor the motor current on the panel ammeter and, if needed, make a manual adjustment of the slide gate. If the hopper is out of media, the ammeter will reduce to some low amperage (called no-load Amps, the value needed to spin the wheel with no media flow). The operator is then expected to replenish the media in the hopper. Conversely, if the media erodes the slide gate, the opening gets larger and the media flow rate increases. This will result in higher motor current, possibly exceeding its rated capacity.

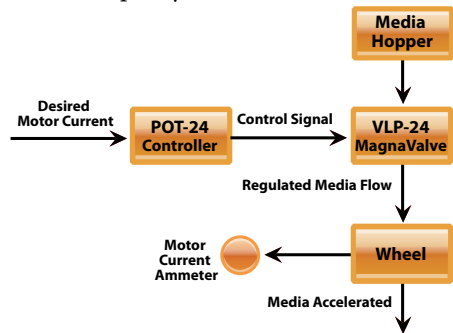

Figure 2. Open-Loop: Magnetic Valve

As shown in Figure 2, a VLP-24 MagnaValve® can be installed with a manual controller, a Pot-24. The advantage of this valve is its inherent simplicity—there are no moving parts in the MagnaValve, only a strong magnetic field to regulate the media flow rate. The controller does not offer any feedback capability but it does provide for a convenient way of setting media flow rate from a remote location. Notice that once again there is no connection from the

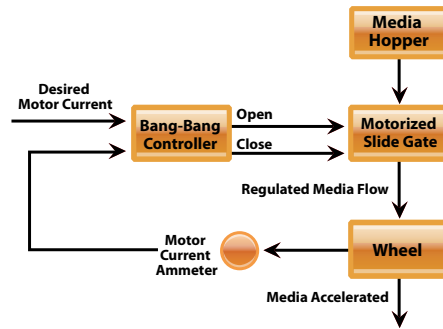

Figure 3. Closed-Loop: Motorized Slide Gate

current meter back to the controller thus no feedback signal is available to compensate for changes in operation conditions.

In the closed-loop system with motorized slide gate in Figure 3, the motor current is monitored and if it is determined to be above or below the desired level, an output relay will momentarily energize a motor which will close or open the slide gate. This type of controller is informally called a bang-bang or on-off controller because it switches abruptly between an on or off state.

In Figure 4, a VLP-24 MagnaValve is operated by an AC-24 Motor Current Controller. The motor current is treated as the system variable. The motor current signal is fed

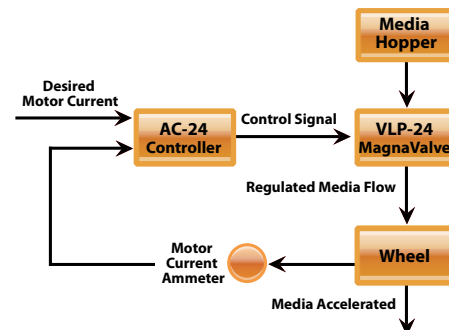

Figure 4. Closed-Loop Magnetic Valve (motor current)

back to the controller which is compared to the requested operating point. The output of the controller to the MagnaValve is then adjusted in order to maintain the expected value.

A closed-loop system with the 500-24 MagnaValve with an internal media flow sensor is illustrated in Figure 5. The 500-24 allows a lb/minute or kg/minute flow rate to be established and maintained. A model FC-24 Controller is used in this configuration. It accepts the flow rate signal from the MagnaValve and compares it to the requested flow rate and then adjusts the output signal to the MagnaValve. ●

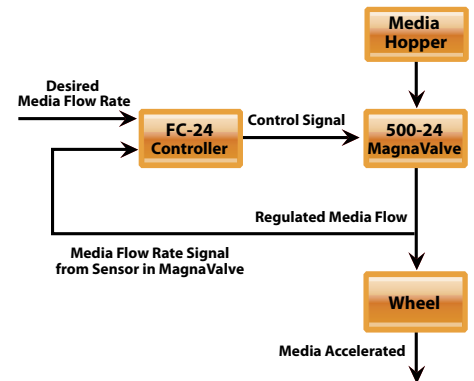

Figure 5. Closed-Loop Magnetic Valve (flow rate)



Electronics Inc.
 Shot Peening Control
 1-800-832-5653 or 1-574-256-5001
 Electronics Inc.
 56790 Magnetic Drive
 Mishawaka, Indiana 46545 USA
 www.electronics-inc.com
 MagnaValve is a registered trademark of Electronics Inc.