

Almen Holder Flatness Gage

999750

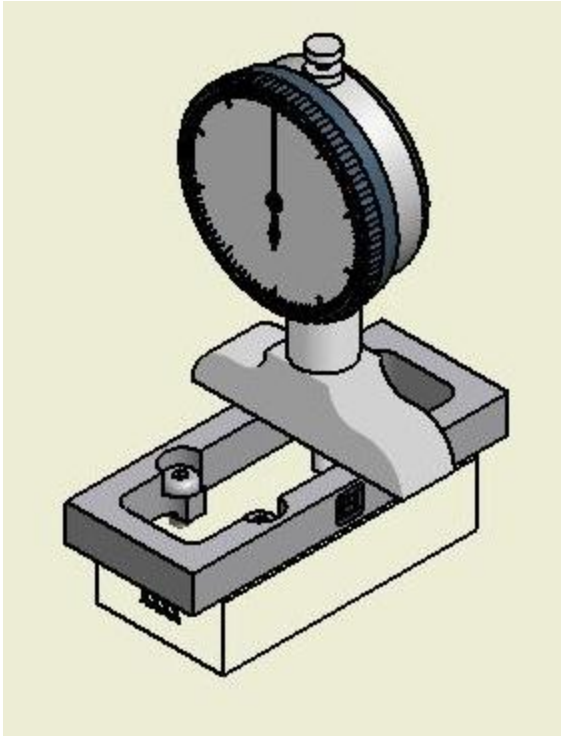

- In-situ flatness check
- SAE J 442
- Satisfies Nadcap audit
- Fast and easy to use

How do you verify flatness of your Almen holder that is rigidly attached to a fixture? It's easy when you have the special Holder Flatness Gage. This simple two-piece design allows you to verify flatness in almost any orientation. Attach the special frame with the (supplied) screws and traverse the indicator over the surface. The dial indicator is graduated 0.0001 inch which will easily exhibit compliance with SAE J 442 flatness limit of ± 0.002 inch.

The screw holes in the frame are designed to verify the accuracy of the holder's screw locations (another Nadcap requirement). The frame holes are oblong to recognize the placement and tolerances of the holes in the holder.

A Product of



56790 Magnetic Drive
<http://www.electronics-inc.com>
Made in America

ELECTRONICS INCORPORATED

Almen Holder Flatness Gage

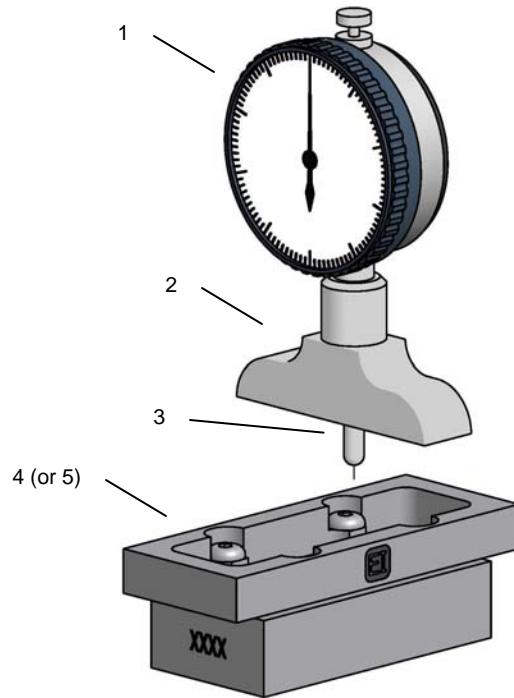
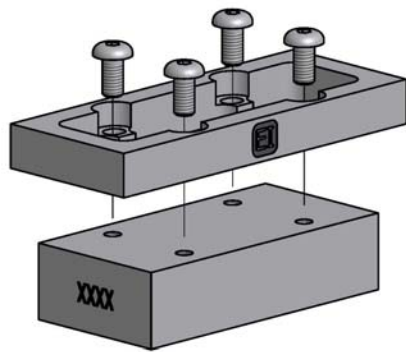

PARTS LIST		
ITEM	CPN	DESCRIPTION
1	970902	DIAL INDICATOR .0001"
2	970903	INDICATOR BASE
3	970904	INDICATOR TIP
4	970900	FLATNESS TESTER FRAME, METERIC
5	970901	FLATNESS TESTER FRAME, INCH

Procedure:

1. Attach the frame to the holder with the four (supplied) screws. If this is successful, the holder hole location is within tolerances required by SAE J 442.
2. Place the dial indicator onto the frame and traverse the entire holder surface.
3. Observe the indicator readings. If they are within ± 0.002 inch then the holder surface flatness is in compliance with SAE J 442.
4. Note: Other specifications may require different flatnesses.