

# MODEL 599-24-1.25-.6 Sensor

SHOT FLOW RATE SENSOR

999344



- Pressure systems
- Gravity Fed systems
- Steel shot/grit
- 2-30 lbs/min
- Steel Pipe Construction
- 0-10Vdc Output
- Standard 1-1/4" NPT Pipe Thread

The Model 599-24-1.25-.6 Inductive Sensor is constructed in a 1-1/4" x 6" steel pipe and should be located above the mixing tee in a direct pressure blasting system. The supplied junction box allows for easy connection of the sensor.

The sensor is placed in the system after the flow rate has been regulated. The sensor detects density of ferrous media and this signal is then scaled to display flow rate.

The 599-24 sensor incorporates a preamplifier circuit to allow for high noise immunity and a 0 - 10 Vdc output.

**ELECTRONICS INCORPORATED**

# MODEL 599-24-1.25-.6 Sensor

## SPECIFICATIONS

Bore:	0.625"
Flow Inlet:	1.25" NPT
Flow Output:	1.25" NPT
Range:	2-30 lb/min
Input:	24Vdc @100mA
Signal:	0-10Vdc

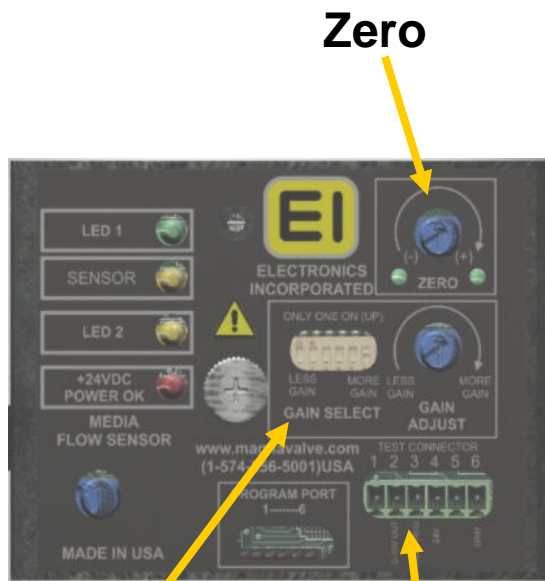
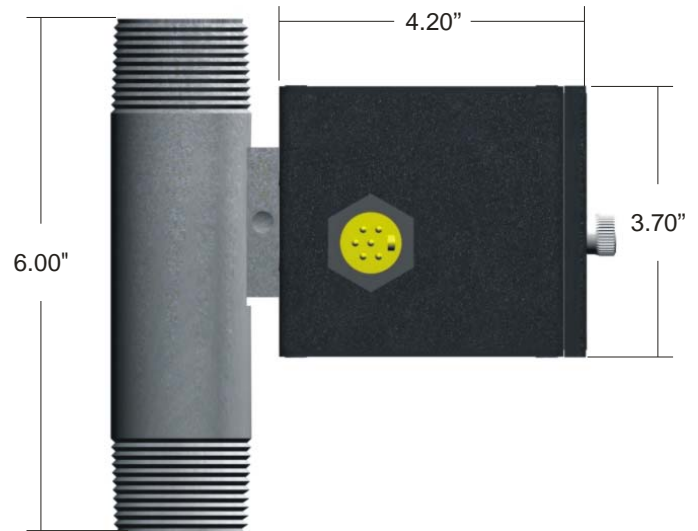
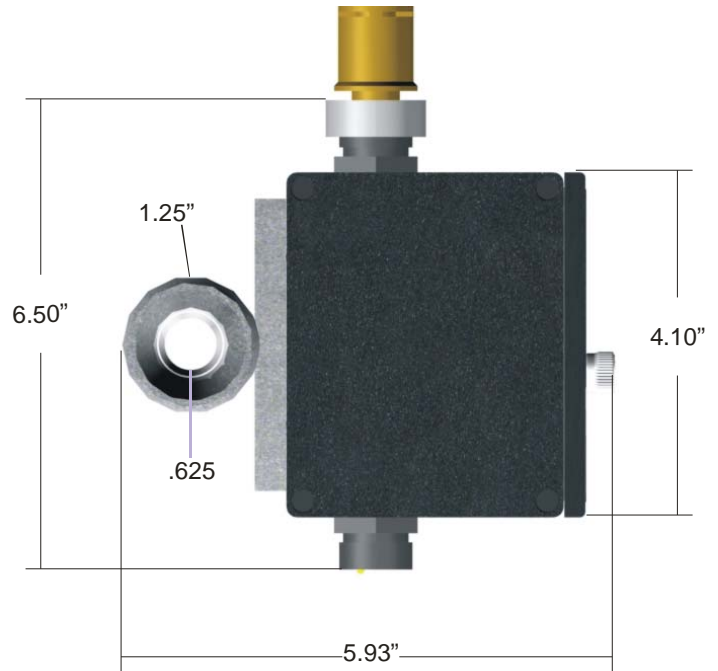

**Gain**

**Test Socket**

1. White – 0-10Vdc output signal
2. Red – 24Vdc power input
3. Green – not used
4. Orange – not used
5. Black – 0V common
6. Blue – not used



1. WHITE
2. RED
3. GREEN
4. ORANGE
5. BLACK
6. BLUE

**ELECTRONICS INCORPORATED**

# MODEL 599-24-1.25-.6 Sensor



**Electronics Inc.**

*Shot Peening Control*

**56790 Magnetic Drive  
Mishawaka, Indiana 46545**

**1-800-832-5653 (Toll Free)  
1-574-256-5001 (Phone)  
1-574-256-5222 (FAX)**

**E-mail: [shotpeener@shotpeener.com](mailto:shotpeener@shotpeener.com)**

**Website: [www.electronics-inc.com](http://www.electronics-inc.com)**

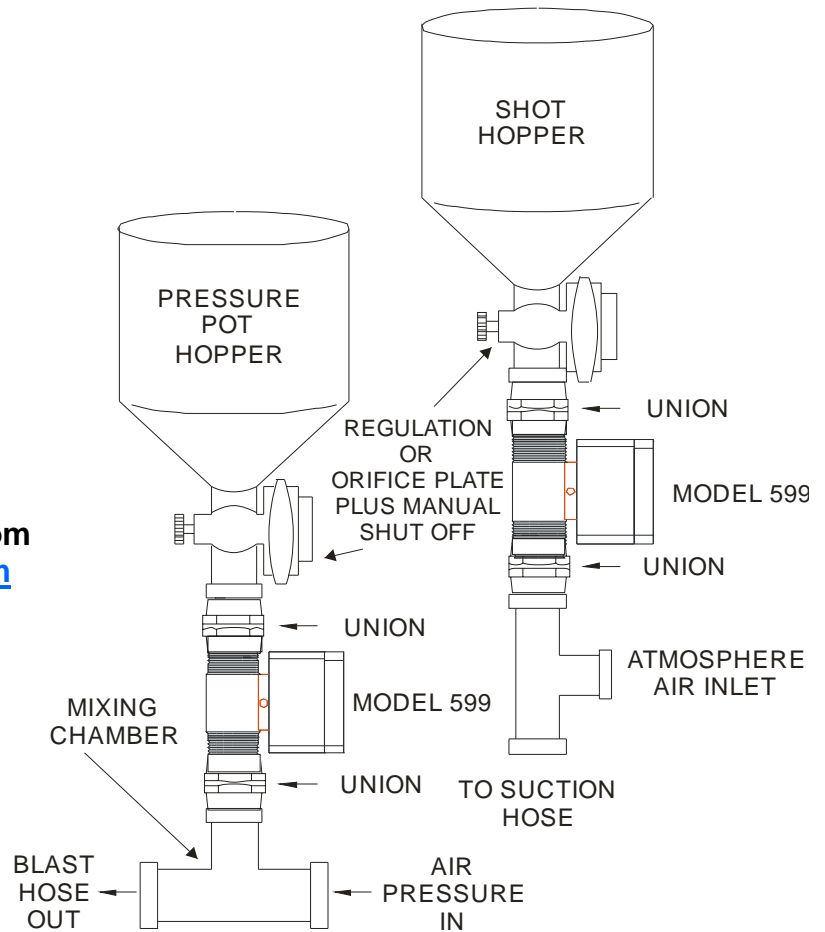

**Zero** – turn adjustment until both LED's are OFF. See manual for more information.



**Test Socket** – This socket provides access to diagnostic voltages.

- 0-10 Vdc input (not used)\*
- 0-10 Vdc output
- Sensor frequency signal (11.7 KHz)
- 24 Vdc power
- 6-20 Hz pulse rate (not used)\*
- 0 Vdc common

\* These points are not used in 599-24 Sensor applications

**Gain** – This section controls the amplification or gain of the sensor signal. It has been factory set (see label for flow range). If you change the gain you will have to run a one-minute catch-and-weigh test to confirm the calibration. The output signal is set to 10 Vdc at the rated flow range.

Note: be sure only one gain switch is selected (up). Use the "Gain Adjust" knob for fine adjustments.

**ELECTRONICS INCORPORATED**