

# \* MODEL 190 MagnaValve \*

Preliminary



- \* On - Off Valve
- \* No moving parts
- \* No air cylinders
- \* Steel shot/grit
- \* Fail Safe permanent Magnet construction

- \* Normally closed
- \* 300 lbs./min.
- \* 110 Vac or
- \* 24 Vdc

The Model 190 MagnaValve is a normally closed magnetic valve typically used to replenish shot hoppers with cast steel shot or cut wire shot.

The valve construction includes a permanent magnet for normally closed operation and an electromagnet to activate shot flow. By applying power to the electromagnet, a full flow condition may be achieved. When power is off, the valve will hold shot due to the permanent magnet.

ELECTRONICS INCORPORATED

# \* MODEL 190 MagnaValve \*

Preliminary

SPECIFICATIONS
VALVE
Input : 80-125VAC @ 2A or 23-25 Vdc @ 2A
Output : 300 lbs./min.
Media: Steel shot
Mode: Normally closed
Temp. Range : 32 - 167° F 0 - 75° C
LED: Red for flow

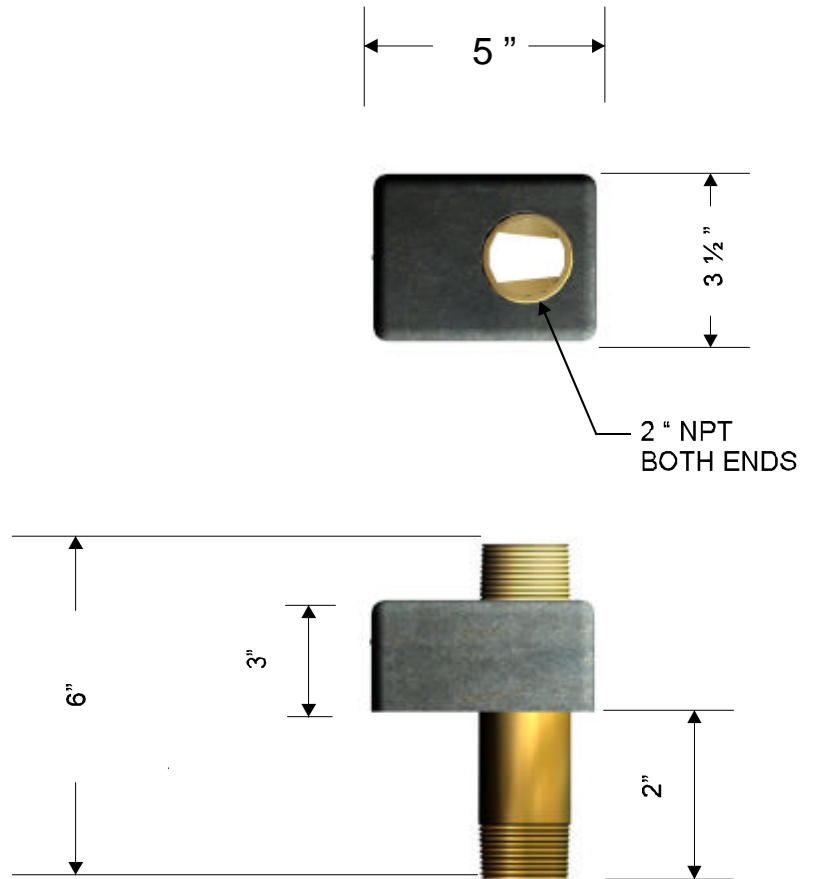

Note: The MagnaValve is designed to operate in a vertical position and must be mounted within 5 degrees of vertical.

Model 190 DC CPN # 999337

Model 190 AC CPN # 999338