

# \* Application Note AN-160 \*

Wire Connections for 577, 578, 579 or 580 MagnaValve to 102 Power Pak and PLC

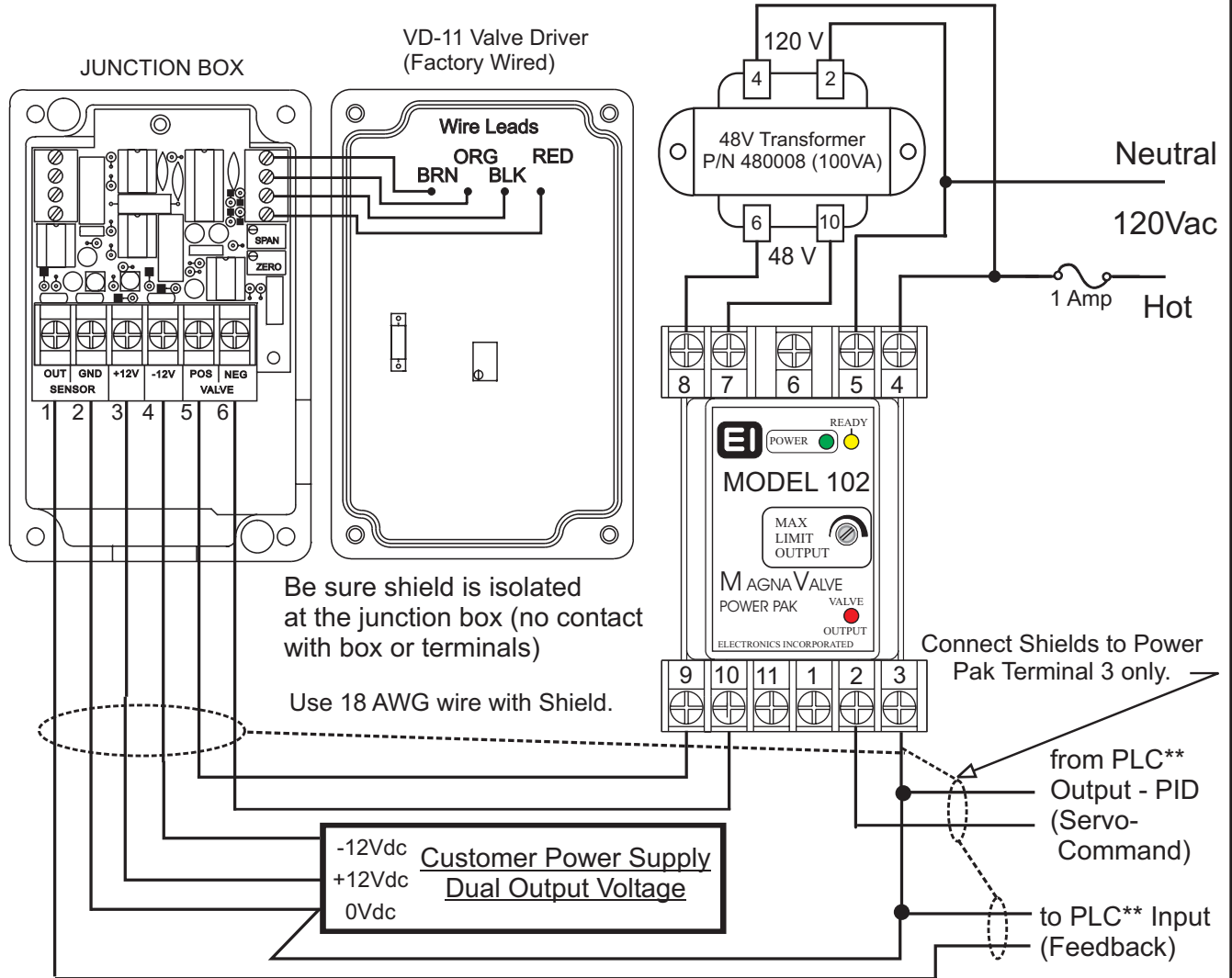

## 102 Power Pak Wiring Connections

1. +5Vdc Excitation Output
2. 0 To +5Vdc Input \*
3. Signal Common
4. Power Hot (120Vac)
5. Power Neutral (120Vac)
6. N/C
7. Transformer (48Vac)
8. Transformer (48Vac)
9. MagnaValve Positive Output
10. MagnaValve Negative Output
11. N/C

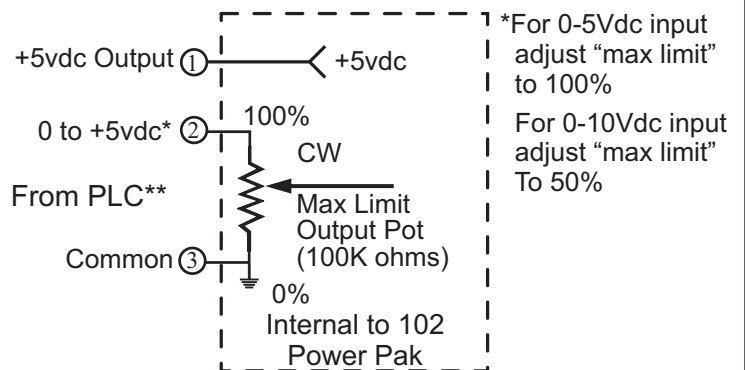

\*\*PLC or Computer must have PID Servo Capability.

\* To use 0 - 10Vdc input adjust max limit output ccw to 50%.

56790 Magnetic Drive Mishawaka, In. USA 46545 (574) 256-5001  
**ELECTRONICS INCORPORATED**